

# DC8016BCD Size 1~6

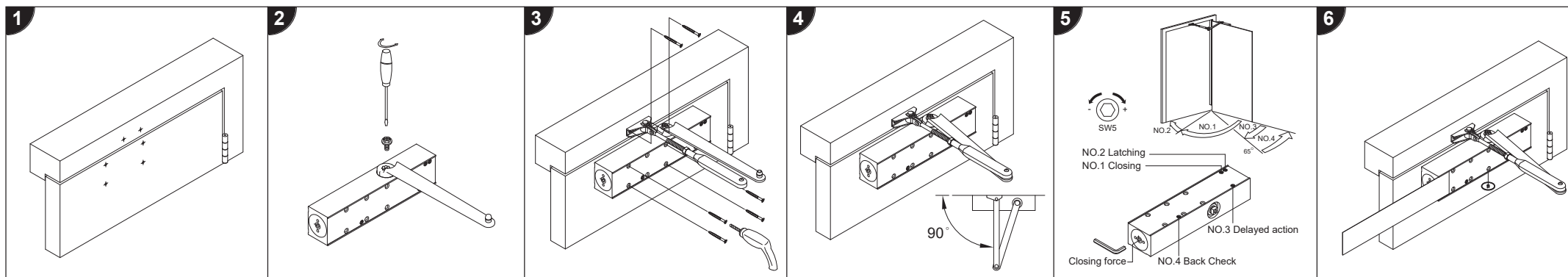

## INSTALLATION INSTRUCTIONS:



## IMPORTANT INSTALLATION NOTES:



### AFTER INSTALLATION, PLEASE CHECK AND TEST:

1. Open the door leaf to its maximum opening angle and release. The door leaf should close fully into the door frame and overcome the latch.
2. Open the door leaf and rest the latch bolt on the striker plate. Release the door leaf. The door closer should have sufficient power to latch the door leaf closed.
3. Back-check provides a cushioning effect when the door is forcibly thrown open but does not serve as substitute for a door stop.



### WARNING:

1. Due to door closer power sizes 1&2 are NOT considered suitable for use fire/smoke door assemblies. Therefore, the minimum spring strength allowed for fire/smoke door assemblies is spring strength 3.
2. The mechanical hold open devices must NOT be installed on fire/smoke door.
3. Door closer should NOT be opened beyond the max. Opening angle of the power size you selected.
4. This door closer contains a powerful spring, which is inserted into the body under pressure. Under circumstances should not attempt to dismantle the door closer.

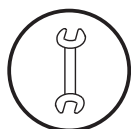

### MAINTENANCE:

1. Check the door closer every three months to ensure all fixings are secure and adjust, if necessary, adjust the closing and latching speed and make the door operating both functionally and smoothly.
2. Apply light oil to arm knuckle joint and door hinges.

### DC8016BCD Power Adjustable Size 1~6

Size	Number of turns	Direction	Max. opening angle
1	0	Counterclockwise	180°
2	0~+2	Counterclockwise	180°
φ3	2~+4	Clockwise	180°
4	+3~+6	Clockwise	180°
5	+6~+9	Clockwise	180°
6	+9~+12	Clockwise	180°

φFACTORY PRE-SET

# Parallel arm fixing application

